

行走减速机驱动轮

型号: ZLX-150-60-10-40-9
 ZLX-150-60-14-40-9
 ZLX-150-60-14-50-27-14.3
 ZLX-150-80-19-50-27-14.3
 ZLX-160-60-14-50-27-14.3
 ZLX-160-80-19-50-27-14.3
 ZLX-180-80-14-60-9
 ZLX-180-80-19-60-9

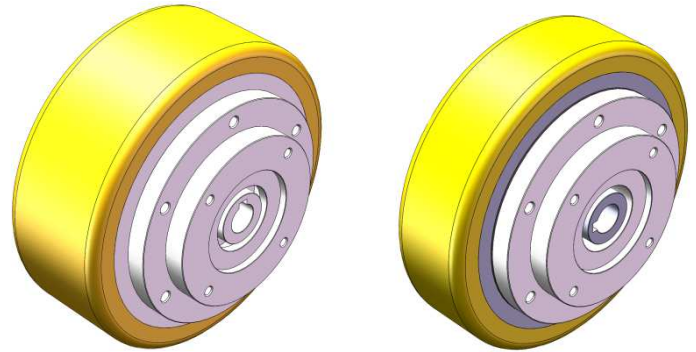

尺寸图:

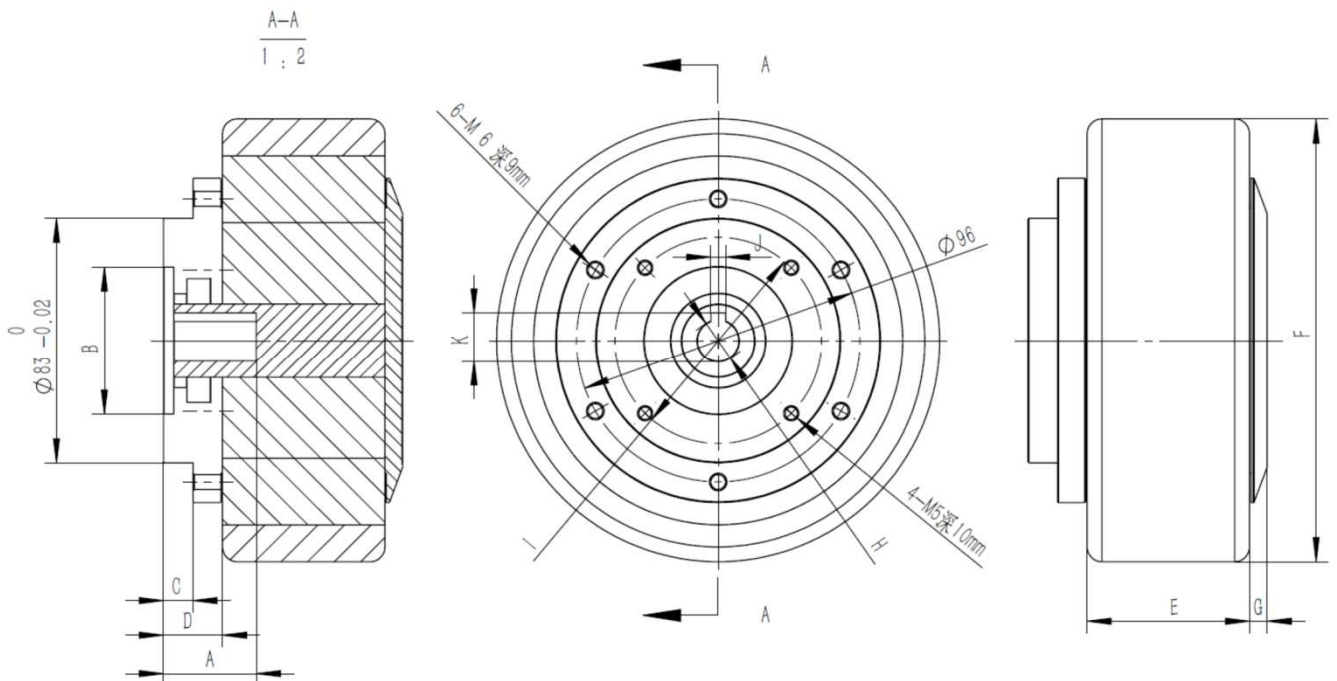

参数表

| 型号 | A | B | C | D | E | F | G | H | I | J | K | 速比 | 速度M/min | 速度M/s |
|------------------|------|----|----|----|----|-----|---|----|----|---|------|------|---------|-------|
| ZLX-150-60-10-40 | 31.5 | 50 | 10 | 20 | 40 | 150 | 6 | 10 | 70 | 3 | 11.5 | 9 | 157.0 | 2.6 |
| ZLX-150-60-14-40 | 31.5 | 50 | 10 | 20 | 40 | 150 | 6 | 14 | 70 | 5 | 16.5 | 9 | 157.0 | 2.6 |
| ZLX-150-60-14-50 | 31.5 | 50 | 10 | 20 | 50 | 150 | 6 | 14 | 70 | 5 | 16.5 | 27 | 52.3 | 0.9 |
| ZLX-150-60-14-50 | 31.5 | 50 | 10 | 20 | 50 | 150 | 6 | 14 | 70 | 5 | 16.5 | 14.3 | 98.8 | 1.6 |
| ZLX-150-60-14-50 | 31.5 | 50 | 10 | 20 | 50 | 150 | 6 | 19 | 70 | 6 | 22 | 27 | 52.3 | 0.9 |
| ZLX-150-60-14-50 | 31.5 | 50 | 10 | 20 | 50 | 150 | 6 | 19 | 70 | 6 | 22 | 14.3 | 98.8 | 1.6 |
| ZLX-160-60-14-50 | 31.5 | 50 | 10 | 20 | 50 | 160 | 6 | 14 | 70 | 5 | 16.5 | 27 | 55.8 | 0.9 |
| ZLX-160-60-14-50 | 31.5 | 50 | 10 | 20 | 50 | 160 | 6 | 14 | 70 | 5 | 16.5 | 14.3 | 105.4 | 1.8 |
| ZLX-160-60-14-50 | 31.5 | 50 | 10 | 20 | 50 | 160 | 6 | 19 | 70 | 6 | 22 | 27 | 55.8 | 0.9 |
| ZLX-160-60-14-50 | 31.5 | 50 | 10 | 20 | 50 | 160 | 6 | 19 | 70 | 6 | 22 | 14.3 | 105.4 | 1.8 |
| ZLX-180-60-14-60 | 31.5 | 50 | 10 | 20 | 60 | 180 | 6 | 14 | 70 | 5 | 16.5 | 27 | 62.8 | 1.0 |
| ZLX-180-80-19-60 | 31.5 | 50 | 10 | 20 | 60 | 180 | 6 | 19 | 70 | 6 | 22 | 27 | 62.8 | 1.0 |

注: 速比可根据实际需求定制。